

Macchine a stati finiti

nicola.basilico@unimi.it

<http://homes.di.unimi.it/basilico/teaching/>

Esercizio 1

- Si realizzi una macchina di Moore in grado di riconoscere le stringhe 010 e 101
 - La macchina riceve in input un bit per volta
 - Quando la macchina riconosce una delle due stringhe dà output 1 altrimenti 0
- Suggerimento: si codifichi l'insieme degli stati come

$$S = \{S_{000}, S_{001}, \dots, S_{111}\}$$

rendendo quindi la macchina in grado di riconoscere una qualsiasi sequenza di 3 bit. Si associ poi un'uscita pari a 1 solo agli stati corrispondenti alle stringhe 010 e 101

Esercizio 1

- Costruiamo il grafo delle transizioni:

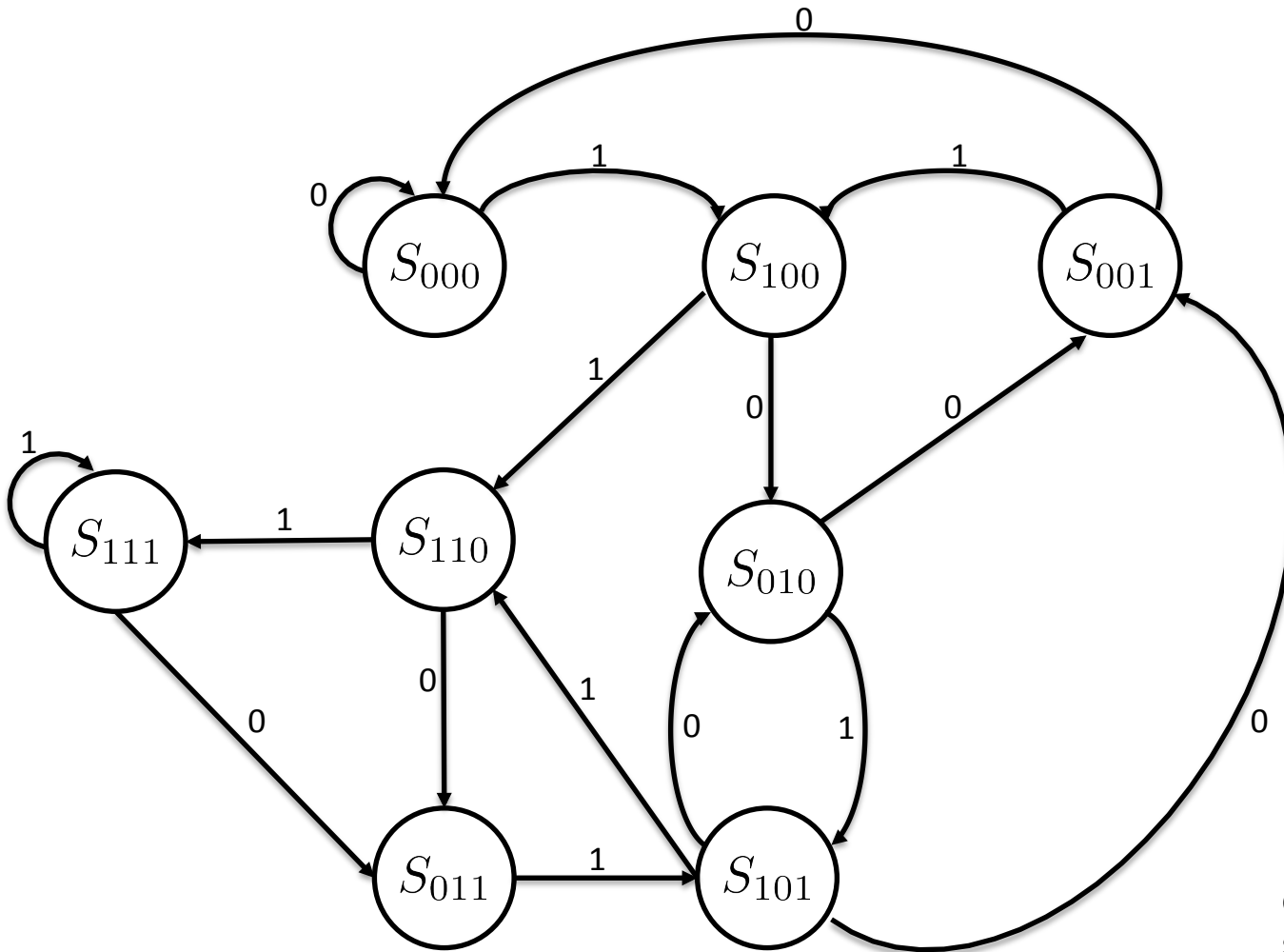

Interpretazione: stato
come registro a
scorrimento verso destra

Esercizio 1

- Tabella delle transizioni:

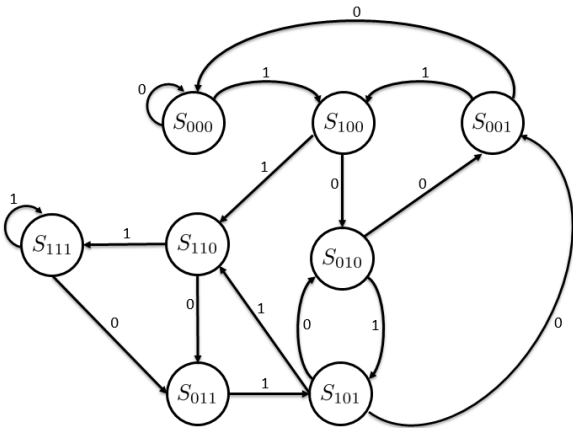

Stato corrente	$x = 0$	$x = 1$	Output
S_{000}	S_{000}	S_{100}	0
S_{001}	S_{000}	S_{100}	0
S_{010}	S_{001}	S_{101}	1
S_{011}	S_{001}	S_{101}	0
S_{100}	S_{010}	S_{110}	0
S_{101}	S_{010}	S_{110}	1
S_{110}	S_{011}	S_{111}	0
S_{111}	S_{011}	S_{111}	0

Esercizio 1

- Codifica degli stati:

Stato corrente $S_{b_0 b_1 b_2}$

Stato prossimo $S_{b'_0 b'_1 b'_2}$

Stato corrente	$x = 0$	$x = 1$	Output
S_{000}	S_{000}	S_{100}	0
S_{001}	S_{000}	S_{100}	0
S_{010}	S_{001}	S_{101}	1
S_{011}	S_{001}	S_{101}	0
S_{100}	S_{010}	S_{110}	0
S_{101}	S_{010}	S_{110}	1
S_{110}	S_{011}	S_{111}	0
S_{111}	S_{011}	S_{111}	0

b_0	b_1	b_2	x	b'_0	b'_1	b'_2	output
0	0	0	0	0	0	0	0
0	0	0	1	1	0	0	0
0	0	1	0	0	0	0	0
0	0	1	1	1	0	0	0
0	1	0	0	0	0	1	1
0	1	0	1	1	0	1	1
0	1	1	0	0	0	1	0
0	1	1	1	1	0	1	0
1	0	0	0	0	1	0	0
1	0	0	1	1	1	0	0
1	0	1	0	0	1	0	1
1	0	1	1	1	1	0	1
1	1	0	0	0	1	1	0
1	1	0	1	1	1	1	0
1	1	1	0	0	1	1	0
1	1	1	1	1	1	1	0

$$b'_0 = x, b'_1 = b_0, b'_2 = b_1$$

$$\text{output} = \bar{b}_0 b_1 \bar{b}_2 + b_0 \bar{b}_1 b_2$$



Esercizio

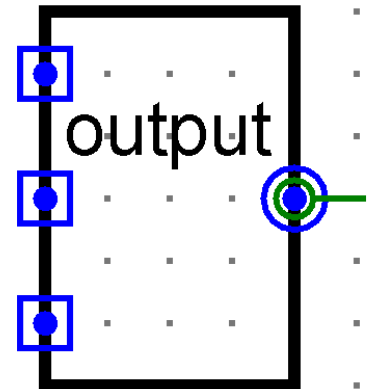
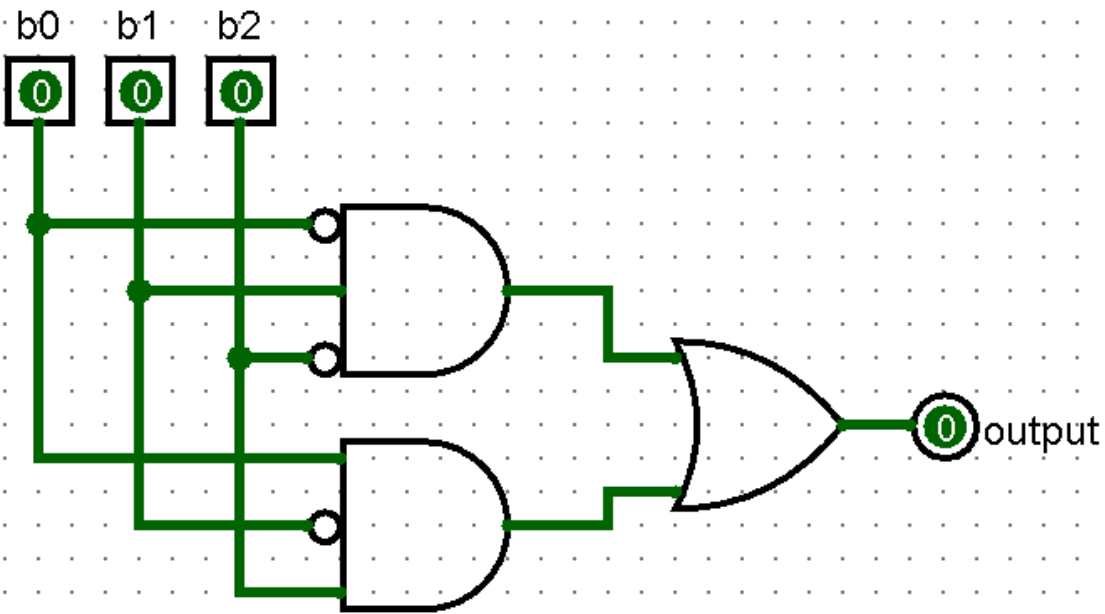

Esercizio 1

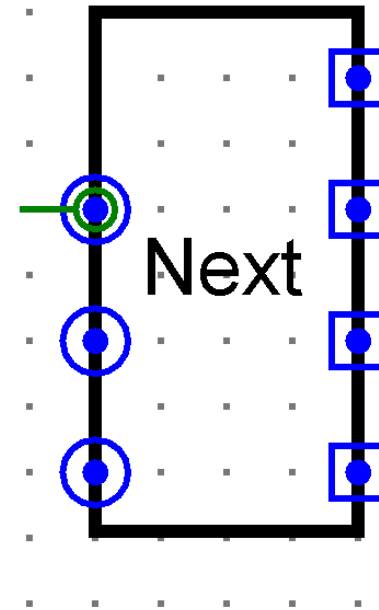
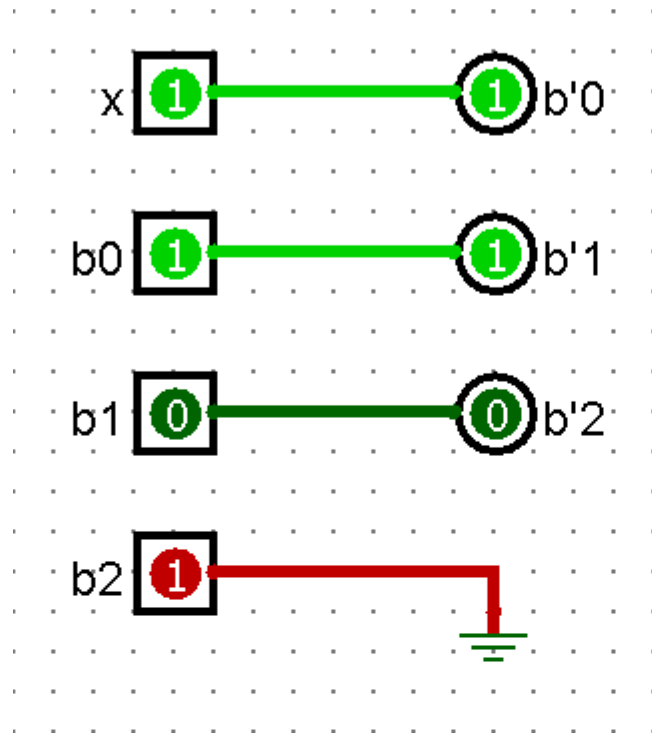

Esercizio 1

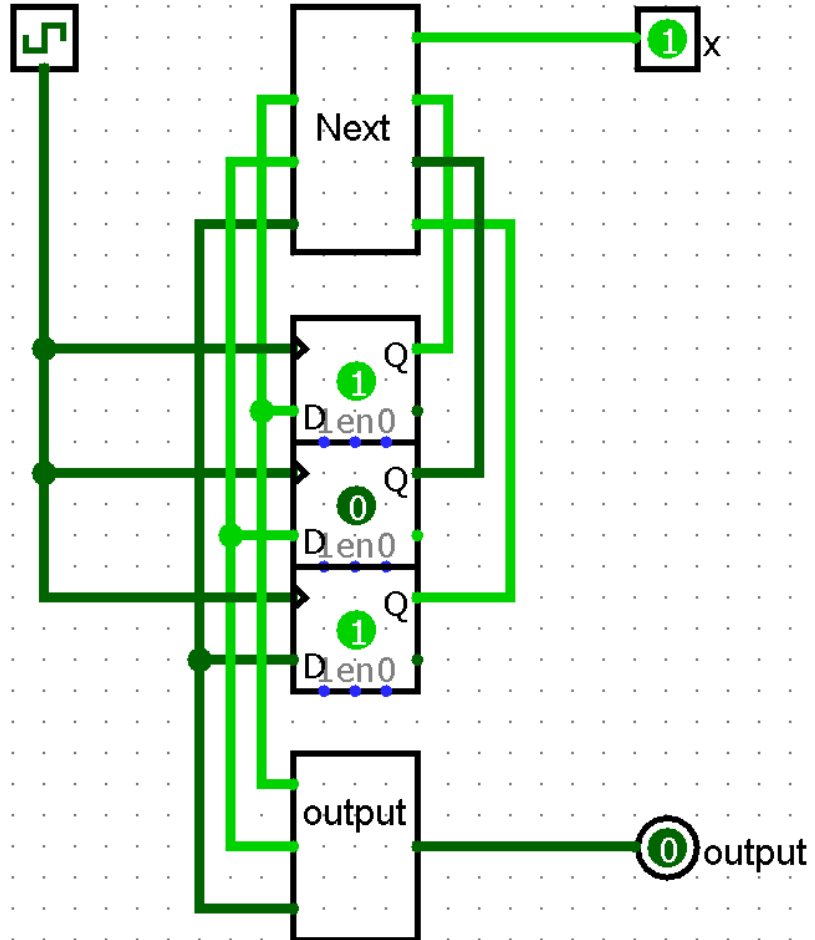

Esercizio 2

- Si realizzi una macchina agli stati finiti di Moore che, date in ingresso due sequenze di 4 bit, dal bit meno significativo ai bit più significativi, realizzi la somma binaria con l'usuale algoritmo aritmetico della somma bit a bit con riporto

Esercizio 2

- Costruiamo il grafo delle transizioni:

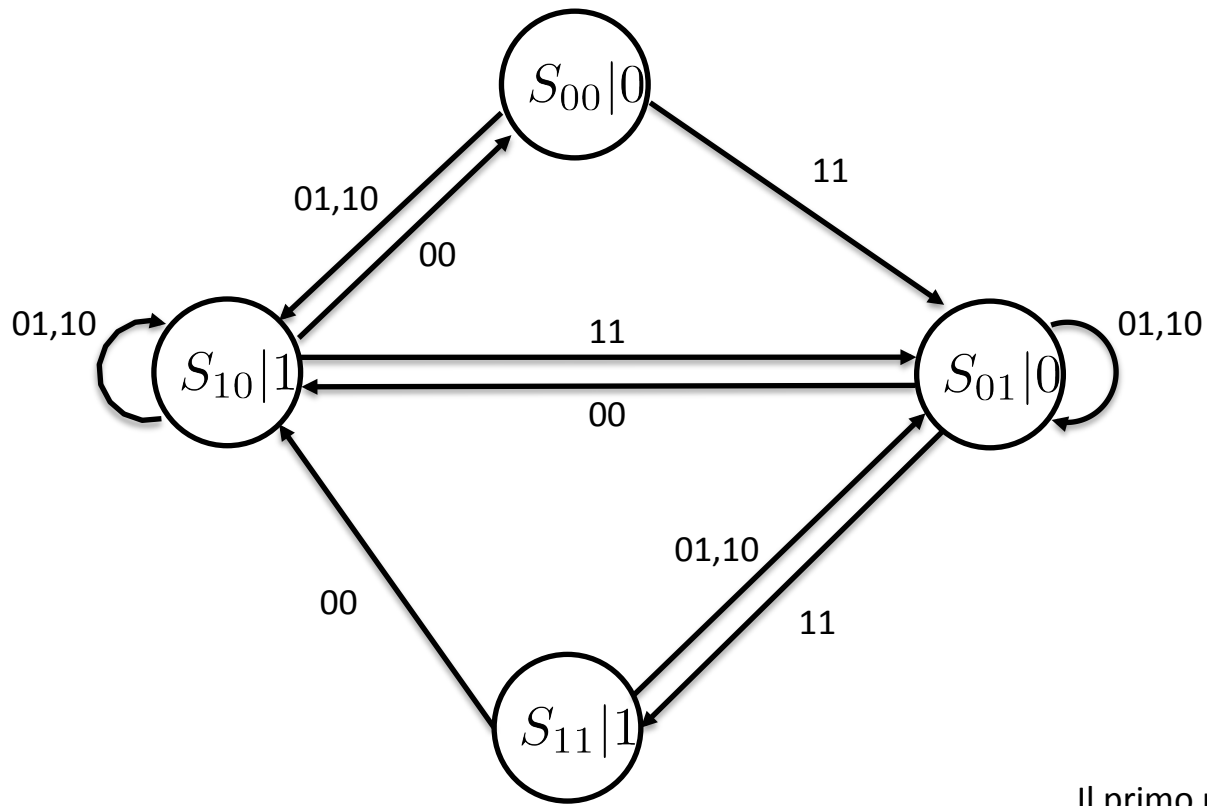

Il primo pedice di S indica il bit S , mentre il secondo pedice indica R

Esercizio 2

- Tabella delle transizioni:

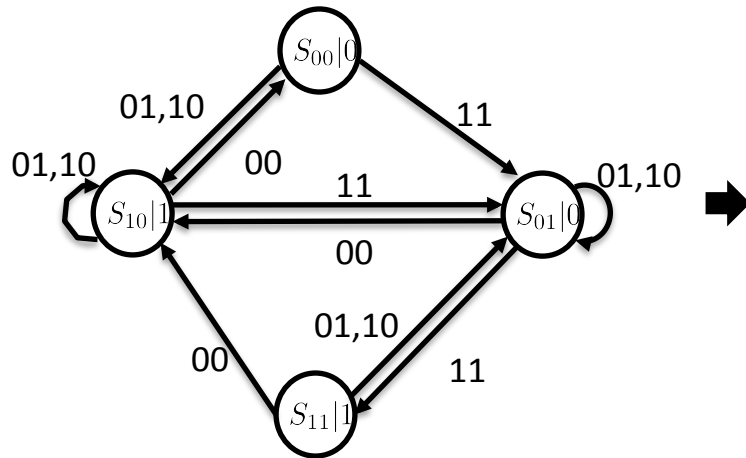

Stato corrente	$AB = 00$	$AB = 01$	$AB = 10$	$AB = 11$	Output
S_{00}	S_{00}	S_{10}	S_{10}	S_{01}	0
S_{10}	S_{00}	S_{10}	S_{10}	S_{01}	1
S_{01}	S_{10}	S_{01}	S_{01}	S_{11}	0
S_{11}	S_{10}	S_{01}	S_{01}	S_{11}	1

Esercizio 2

- Codifica degli stati:

Stato corrente S_{SR}

Stato prossimo $S_{S'R'}$

Stato corrente	$AB = 00$	$AB = 01$	$AB = 10$	$AB = 11$	Output
S_{00}	S_{00}	S_{10}	S_{10}	S_{01}	0
S_{10}	S_{00}	S_{10}	S_{10}	S_{01}	1
S_{01}	S_{10}	S_{01}	S_{01}	S_{11}	0
S_{11}	S_{10}	S_{01}	S_{01}	S_{11}	1

S	R	A	B	S'	R'	output
0	0	0	0	0	0	0
0	0	0	1	1	0	0
0	0	1	0	1	0	0
0	0	1	1	0	1	0
1	0	0	0	0	0	1
1	0	0	1	1	0	1
1	0	1	0	1	0	1
1	0	1	1	0	1	1
0	1	0	0	1	0	0
0	1	0	1	0	1	0
0	1	1	0	0	1	0
0	1	1	1	1	1	0
1	1	0	0	1	0	1
1	1	0	1	0	1	1
1	1	1	0	0	1	1
1	1	1	1	1	1	1

Esercizio 2

- Codifica degli stati:

Stato corrente S_{SR}

Stato prossimo $S_{S'R'}$

Stato corrente	$AB = 00$	$AB = 01$	$AB = 10$	$AB = 11$	Output
S_{00}	S_{00}	S_{10}	S_{10}	S_{01}	0
S_{10}	S_{00}	S_{10}	S_{10}	S_{01}	1
S_{01}	S_{10}	S_{01}	S_{01}	S_{11}	0
S_{11}	S_{10}	S_{01}	S_{01}	S_{11}	1

S	R	A	B	S'	R'	output
0	0	0	0	0	0	0
0	0	0	1	1	0	0
0	0	1	0	1	0	0
0	0	1	1	0	1	0
1	0	0	0	0	0	1
1	0	0	1	1	0	1
1	0	1	0	1	0	1
1	0	1	1	0	1	1
0	1	0	0	1	0	0
0	1	0	1	0	1	0
0	1	1	0	0	1	0
0	1	1	1	1	1	0
1	1	0	0	1	0	1
1	1	0	1	0	1	1
1	1	1	0	0	1	1
1	1	1	1	1	1	1

$$S' = (A \text{ XOR } B) \text{ XOR } R$$

$$R' = (A \text{ XOR } B)R + AB$$

$$\text{output} = S$$

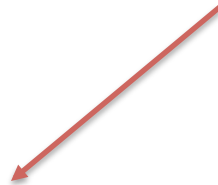

Esercizio 2

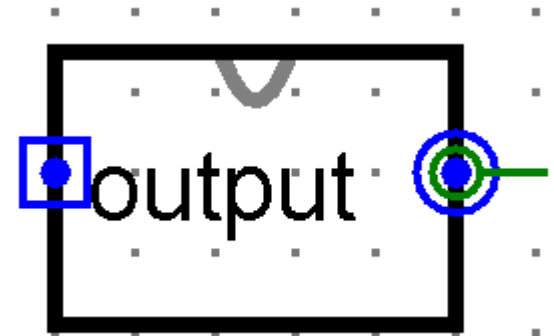

Esercizio 2

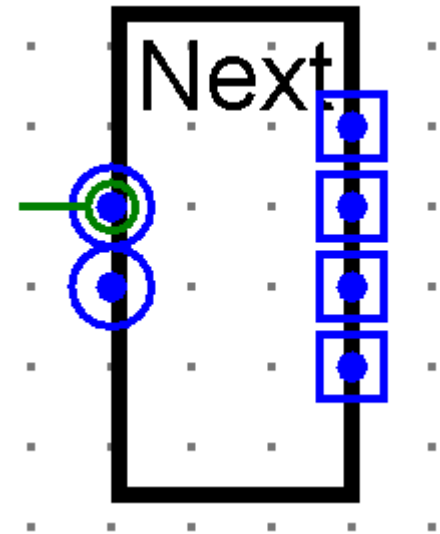
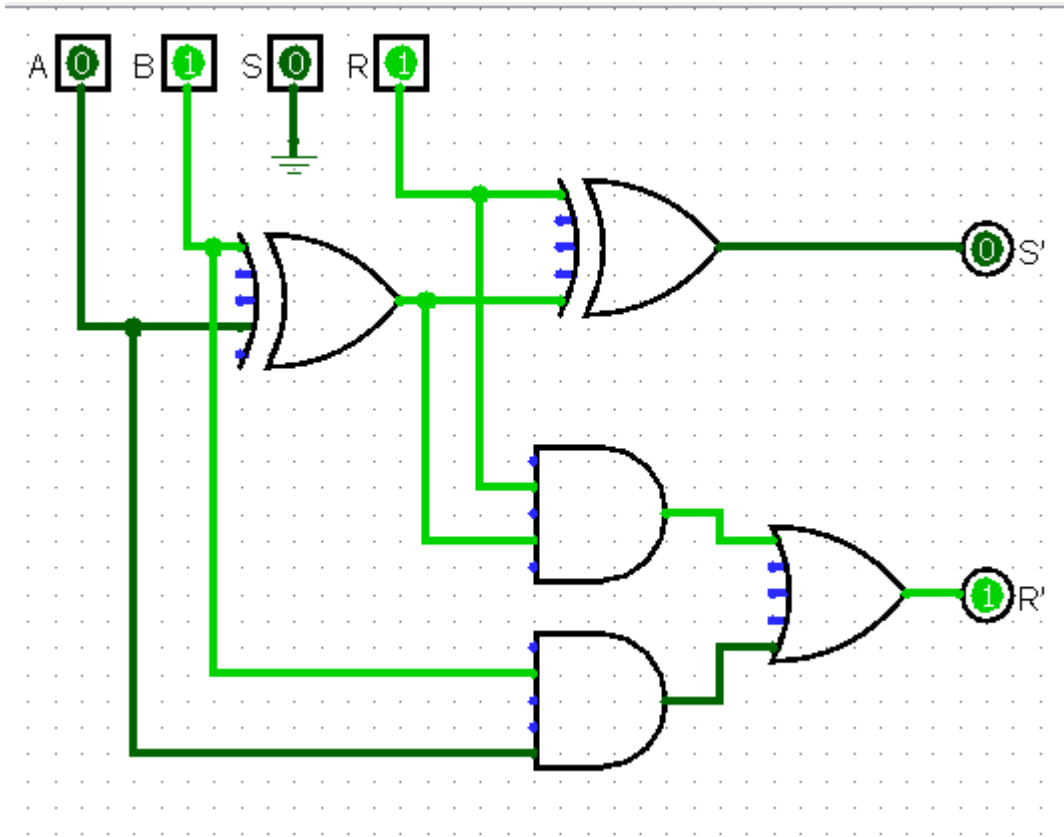

Esercizio 2

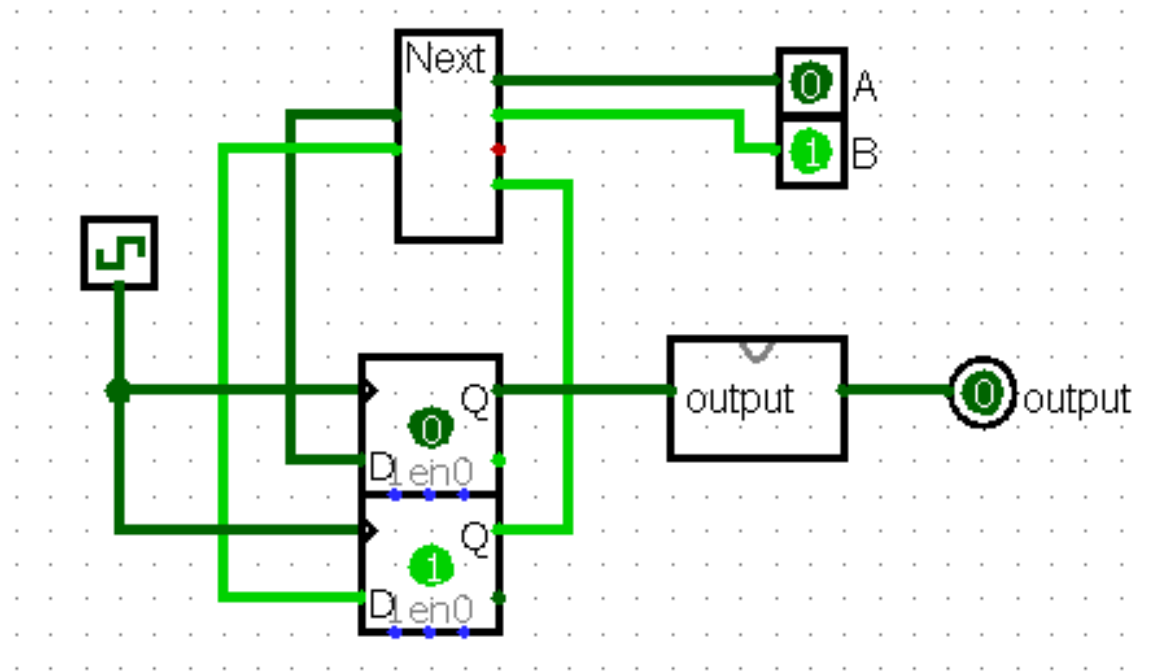

Esercizio 2

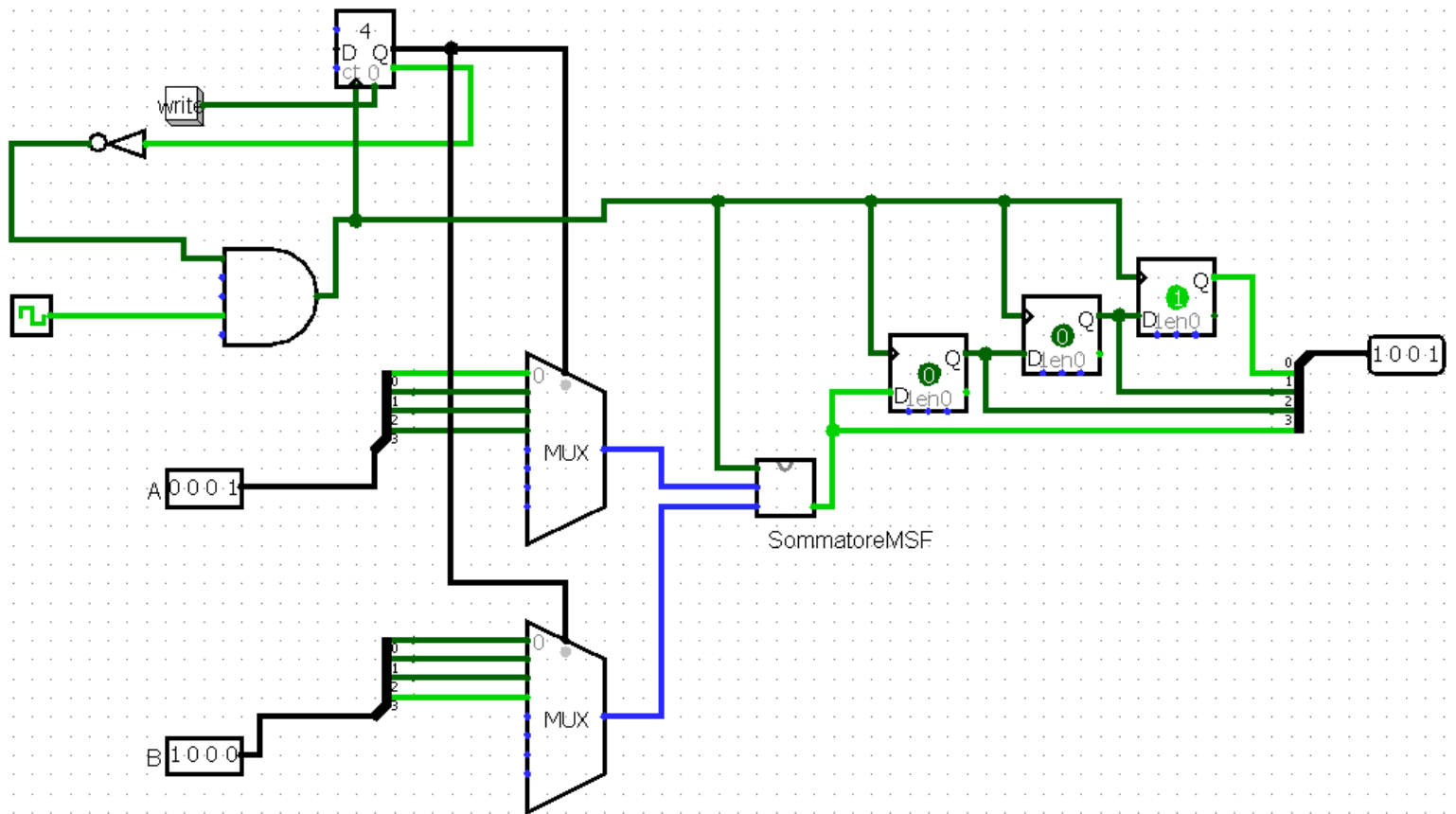

Esercizio 3

- Costruire una macchina a stati finiti (di Moore) con due ingressi, x_1 e x_2 , che fornisca 1 quando negli ultimi 3 istanti di tempo si è verificata la seguente condizione:

	$t = -2$	$t = -1$	$t = 0$
x_1	0	X	1
x_2	0	1	0